

TOWER-SV / TOWER-SH

Roof-mounted centrifugal smoke extraction fans

Use

- Smoke extraction fans are used in emergency exhaust ventilation systems for forced extraction of smoke and heated gases and simultaneous transfer of heat away and beyond the limits of the serviced spaces in case of fire.
- Such units are used in production, public, residential, administrative and other spaces.



Air flow:
up to 105 000 m³/h



Transported air temperature:
600 °C/2 hours



Operation

- The fans are capable of handling smoke and air mixtures with temperatures up to +600 °C for 120 minutes.
- The fans can operate in conjunction with a frequency converter (herein-after referred to as FC) or directly when connected to power supply. The relevant characteristics for these modes are listed in the tables below.
- The fan can be used for general exhaust ventilation at a rotational speed reduced by at least 25 % of the nominal speed of the electric motor.
- The fan can be designed for moderate (**U**) or tropical (**T**) climate conditions.

Design

- The fans are made of heat resistant steel with polymer coating providing weathering resistance.
- There are two types of roof-mounted smoke extraction fans: with horizontal air discharge (**Tower-SH**) and vertical air discharge (**Tower-SV**).
- The models with vertical air discharge are equipped with a backdraft damper. The fan has a protective grille to prevent accidental contact and penetration of foreign objects. The impeller with backward curved blades is painted with powder coating.

Motor

- The fans are equipped with three-phase electric motors rated for 400 V.
- The motor is located in the compartment offset from the transported air stream. Motor ingress protection rating is IP54.

Mounting

- The roof fans are installed on the **MRDL** (simplified version) or **MIRDL** mounting frame (heat-insulated version).
- The **MRDL** and **MIRDL** mounting frames are designed for mounting the fan on the roof without a slope.
- Make sure that the location provides for sufficient space as required for the fan maintenance.



MRDL 630
MRDL 710-800
MRDL 900
MRDL 1000-1100

Designation key

	TOWER-S	V	630	1.5/720	M	Zn
Fan series: Roof-mounted smoke extraction fan						
Air discharge direction: V: vertical H: horizontal						
Impeller diameter [mm]: 630; 710; 800; 900; 1000; 1100						
Rated power of the electric motor [kW] / Motor speed [RPM]: 1.5...37/720...1470						
Terminal box: _: no terminal box M: terminal box						
_: RAL7040 gray by default RALxxx: paint colour according to RALxxx Zn: galvanized steel						

Overall dimensions [mm]

Model	H	H1	L1	L2	L3	L4	∅ D	∅ D1	∅ D2	∅ d1	∅ d2	n	Weight [kg]	MRDL, MIRDL mounting frame compatibility	
Tower-SV(SH) 630 1.5/930	1038	302	1424	750	955	1153	503	541	634	10	21	12	200	MRDL/MIRDL 630	
Tower-SV(SH) 630 2.2/940		210											225		216
Tower-SV(SH) 630 3/960	1043	307	1424	750	955	1153	503	541	634	10	21	12	225		
Tower-SV(SH) 630 4/1440	1038	302											216		230
Tower-SV(SH) 630 5.5/1450	1043	307	1424	750	955	1153	503	541	634	10	21	12	230		
Tower-SV(SH) 630 7.5/1440	1134												255		
Tower-SV(SH) 710 2.2/940	1181	317	1508	840	1040	1238	633	674	730	12	21	16	242		MRDL/MIRDL 710-800
Tower-SV(SH) 710 3/960	1186	322											252		
Tower-SV(SH) 710 4/950			253												
Tower-SV(SH) 710 5.5/960	280														
Tower-SV(SH) 710 7.5/1455	281														
Tower-SV(SH) 710 11/1460	292														
Tower-SV(SH) 800 4/960	1239	345	1543	840	1040	1238	633	674	784	12	21	16	286		
Tower-SV(SH) 800 5.5/950													305		
Tower-SV(SH) 800 7.5/970	1335	355	1543	840	1040	1238	633	674	784	12	21	16	312		
Tower-SV(SH) 800 11/960													390		
Tower-SV(SH) 800 15/1460	390														
Tower-SV(SH) 800 18.5/1470	395														
Tower-SV(SH) 900 4/720	1379	363	1871	1050	1200	1398	713	751	874	12	21	16	376	MRDL/MIRDL 900	
Tower-SV(SH) 900 5.5/960	376														
Tower-SV(SH) 900 7.5/970	1398	372	1871	1050	1200	1398	713	751	874	12	21	16	380		
Tower-SV(SH) 900 11/970													418		
Tower-SV(SH) 900 15/960	433														
Tower-SV(SH) 900 18.5/960	482														
Tower-SV(SH) 900 22/960	566														
Tower-SV(SH) 1000 5.5/720	1365	398	2111	1240	1430	1628	803	837	974	12	23	24	467		MRDL/MIRDL 1000-1100
Tower-SV(SH) 1000 7.5/730	1573	403											588		
Tower-SV(SH) 1000 11/970			590												
Tower-SV(SH) 1000 15/970	595														
Tower-SV(SH) 1000 18.5/970	639														
Tower-SV(SH) 1000 22/970	670														
Tower-SV(SH) 1000 30/970	690														
Tower-SV(SH) 1100 11/730	720														
Tower-SV(SH) 1100 15/730	775														
Tower-SV(SH) 1100 18.5/970	1721	441	2236	1240	1430	1628	903	934	1075	12	23	24	763		
Tower-SV(SH) 1100 22/970	794														
Tower-SV(SH) 1100 30/970	812														
Tower-SV(SH) 1100 37/980	1773												930		

ROOF-MOUNTED SMOKE EXTRACTION FANS

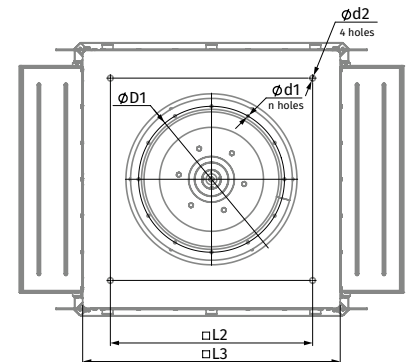
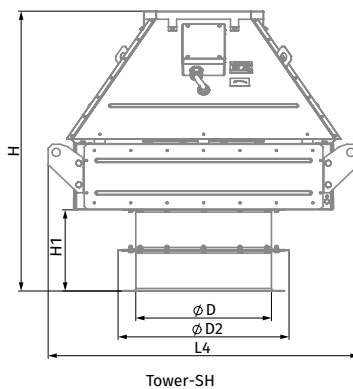
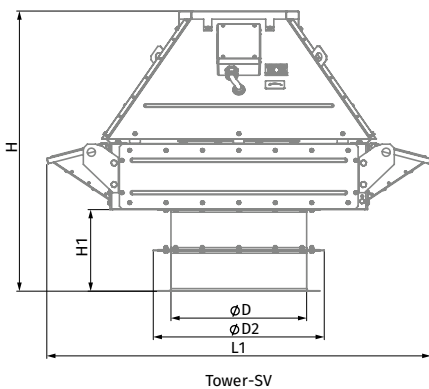

Overall dimensions of MRDL and MIRDL mounting frames [mm]

Model	A	B	C	H	M	Weight MRDL [kg]	Weight MIRDL [kg]
MRDL/MIRDL 630	1212	912	750	600	M18	65.9	85.45
MRDL/MIRDL 710-800	1262	962	840	600	M18	68.5	89.04
MRDL/MIRDL 900	1512	1212	1050	650	M18	85.7	113
MRDL/MIRDL 1000-1100	1712	1412	1240	730	M20	103.7	140.59

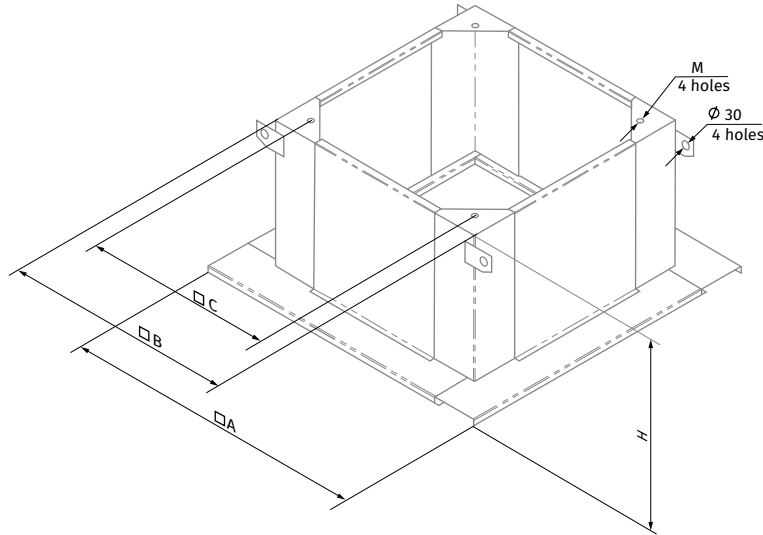

Technical data

Parameters	Tower-SV/SH 630 1.5/930	Tower-SV/SH 630 2.2/940	Tower-SV/SH 630 3.0/960	Tower-SV/SH 630 4.0/1440	Tower-SV/SH 630 5.5/1450	Tower-SV/SH 630 7.5/1440
Voltage [V]	3~400	3~400	3~400	3~400	3~400	3~400
Rated frequency [Hz]	50	50	50	50	50	50
Rated power Ny [kW]	1.5	2.2	3.0	4.0	5.5	7.5
Rated current [A]	3.7	5.6	7.4	8.8	11.3	15.5
Rated RPM [min ⁻¹]	930	940	960	1440	1450	1440
Maximum RPM when operating from FC [min ⁻¹]	1010	1160	1280	1370	1550	1730
Maximum frequency when operating from FC [Hz]	54	62	67	48	53	60
Curve number at the diagram when operating from FC	①	②	③	④	⑤	⑥
Curve number at the diagram when operating from supply network	⑦	⑧	⑨	-	⑩	⑪

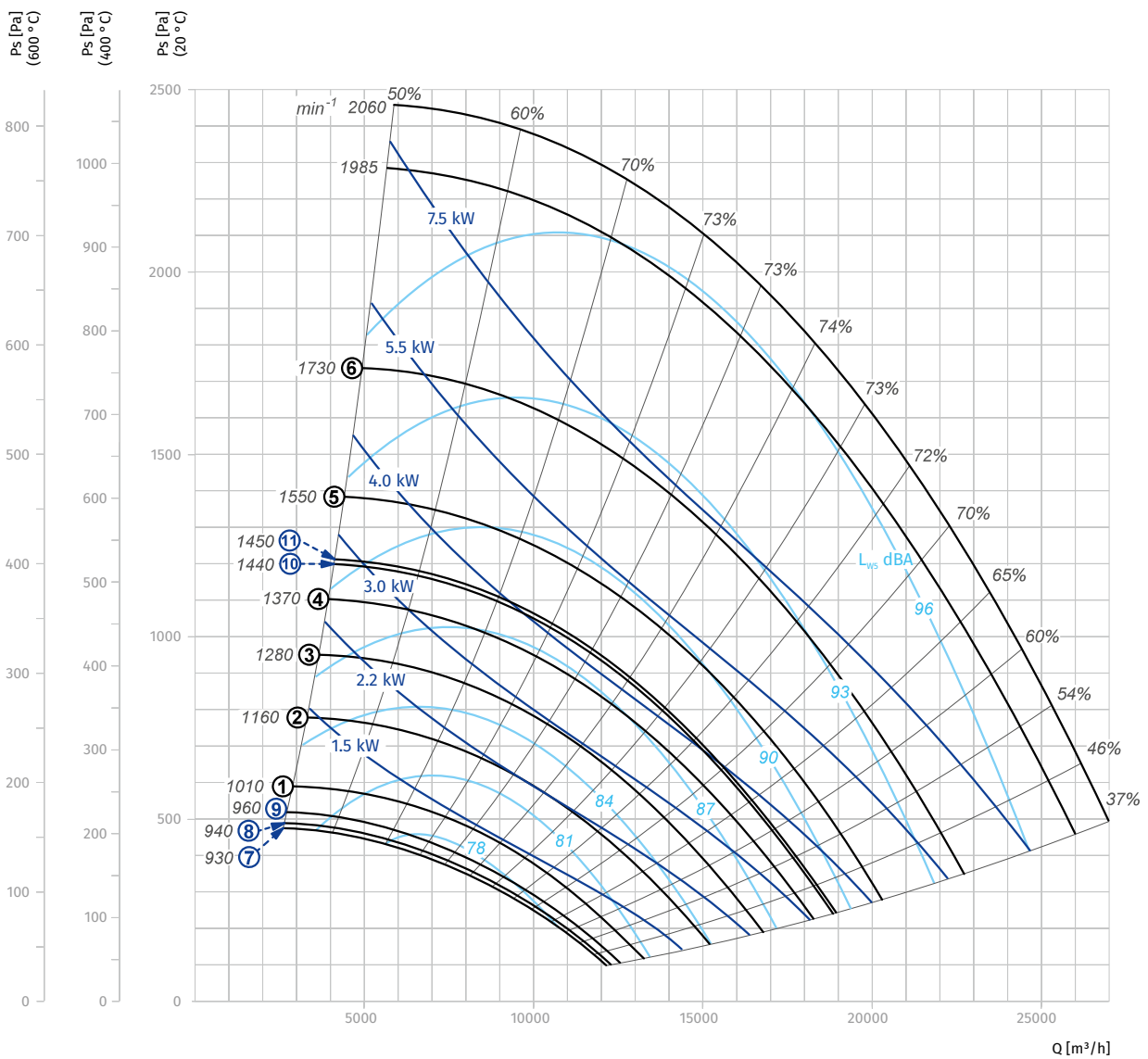

Parameters	Tower-SV/SH 710 2.2/940	Tower-SV/SH 710 3/960	Tower-SV/SH 710 4/950	Tower-SV/SH 710 5.5/960	Tower-SV/SH 710 7.5/1455	Tower-SV/SH 710 11/1460
Voltage [V]	3~400	3~400	3~400	3~400	3~400	3~400
Rated frequency [Hz]	50	50	50	50	50	50
Rated power Ny [kW]	2.2	3.0	4.0	5.5	7.5	11.0
Rated current [A]	5.3	7.4	8.4	11.2	15.1	21.2
Rated RPM [min ⁻¹]	940	960	950	960	1455	1460
Maximum RPM when operating from FC [min ⁻¹]	940	1050	1140	1280	1380	1620
Maximum frequency when operating from FC [Hz]	50	55	60	67	47	55
Curve number at the diagram when operating from FC	①	②	③	④	⑤	⑥
Curve number at the diagram when operating from supply network	⑦	⑨	⑧	⑨	-	⑩

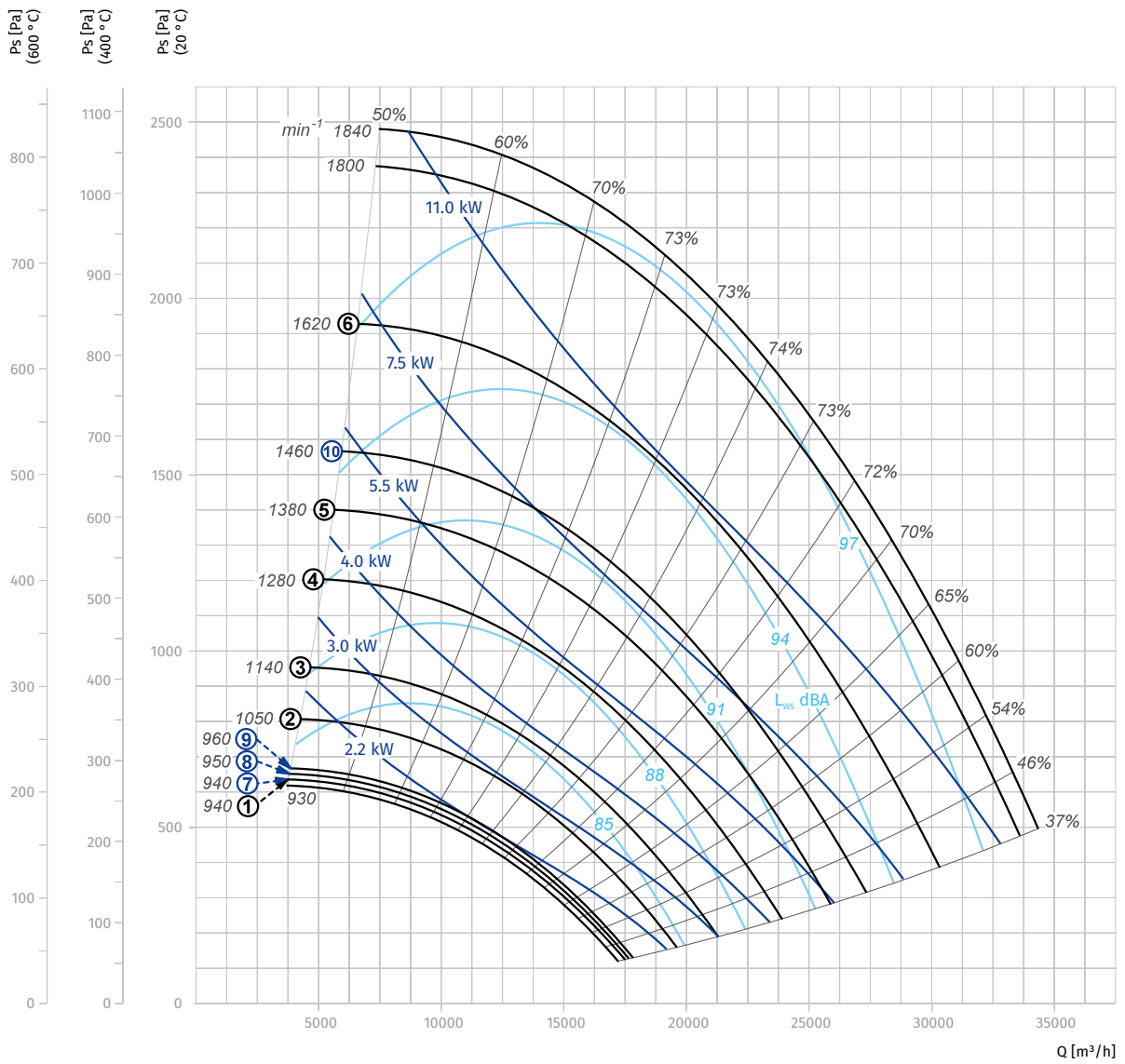

Parameters	Tower-SV/SH 800 4/960	Tower-SV/SH 800 5.5/950	Tower-SV/SH 800 7.5/970	Tower-SV/SH 800 11/960	Tower-SV/SH 800 15/1460	Tower-SV/SH 800 18.5/1470
Voltage [V]	3~400	3~400	3~400	3~400	3~400	3~400
Rated frequency [Hz]	50	50	50	50	50	50
Rated power Ny [kW]	4.0	5.5	7.5	11.0	15.0	18.5
Rated current [A]	9.2	12.3	15.7	21.2	29.5	36.4
Rated RPM [min ⁻¹]	960	950	970	960	1460	1470
Maximum RPM when operating from FC [min ⁻¹]	960	1050	1170	1330	1480	1580
Maximum frequency when operating from FC [Hz]	50	55	60	69	51	54
Curve number at the diagram when operating from FC	①	②	③	④	⑤	⑥
Curve number at the diagram when operating from supply network	⑧	⑦	⑨	⑧	⑩	⑪

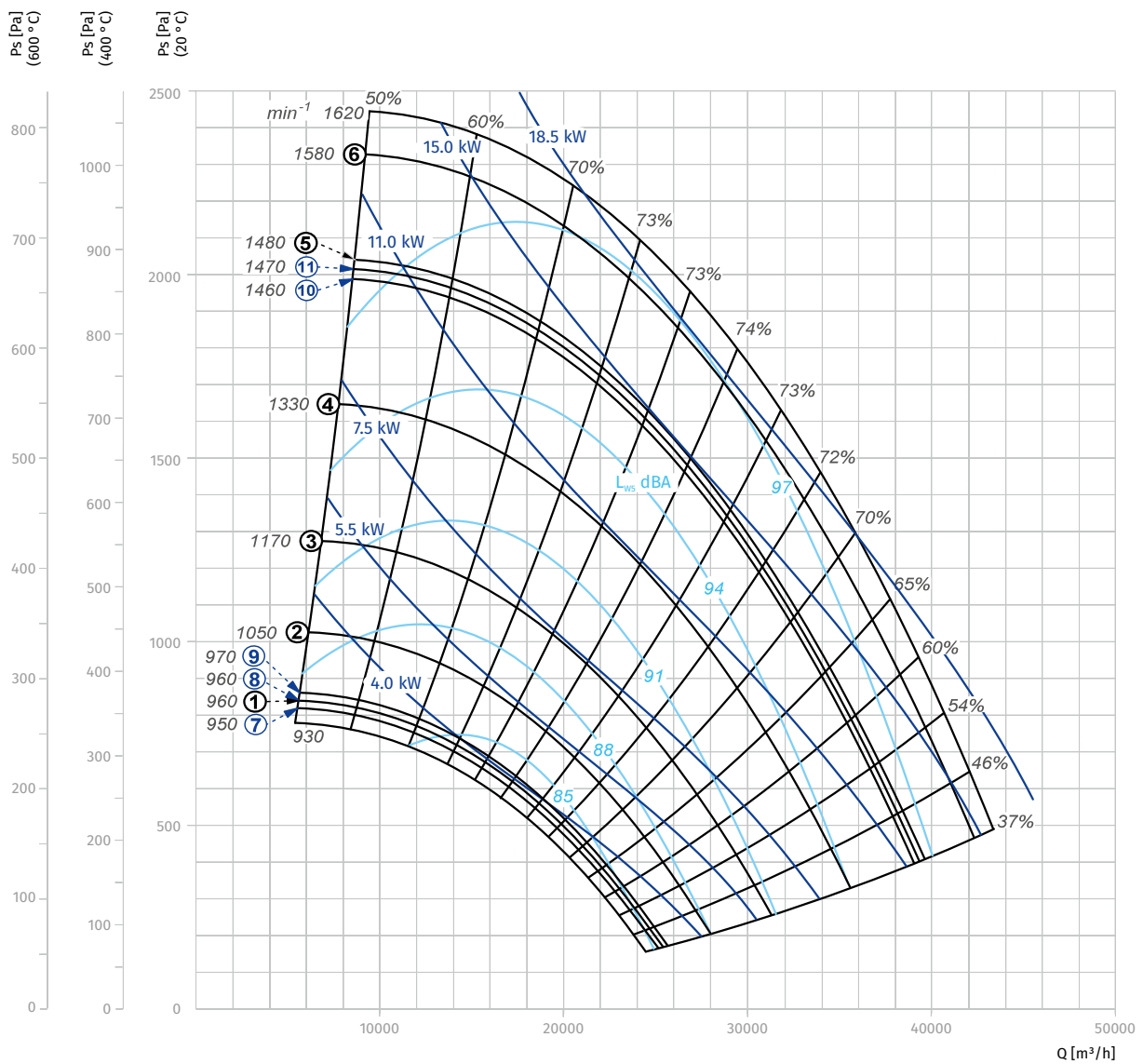

ROOF-MOUNTED SMOKE EXTRACTION FANS

Parameters	Tower-SV/SH 900 4/720	Tower-SV/SH 900 5.5/960	Tower-SV/SH 900 7.5/970	Tower-SV/SH 900 11/970	Tower-SV/SH 900 15/960	Tower-SV/SH 900 18.5/960	Tower-SV/SH 900 22/960
Voltage [V]	3~400	3~400	3~400	3~400	3~400	3~400	3~400
Rated frequency [Hz]	50	50	50	50	50	50	50
Rated power Ny [kW]	4.0	5.5	7.5	11.0	15.0	18.5	22.0
Rated current [A]	10.0	12.3	15.7	23	31.0	36.4	44
Rated RPM [min ⁻¹]	720	960	970	970	960	960	960
Maximum RPM when operating from FC [min ⁻¹]	770	860	970	1070	1210	1290	1370
Maximum frequency when operating from FC [Hz]	53	45	50	55	63	67	71
Curve number at the diagram when operating from FC	①	②	③	④	⑤	⑥	⑦
Curve number at the diagram when operating from supply network	⑧	-	⑩	⑩	⑨	⑨	⑨

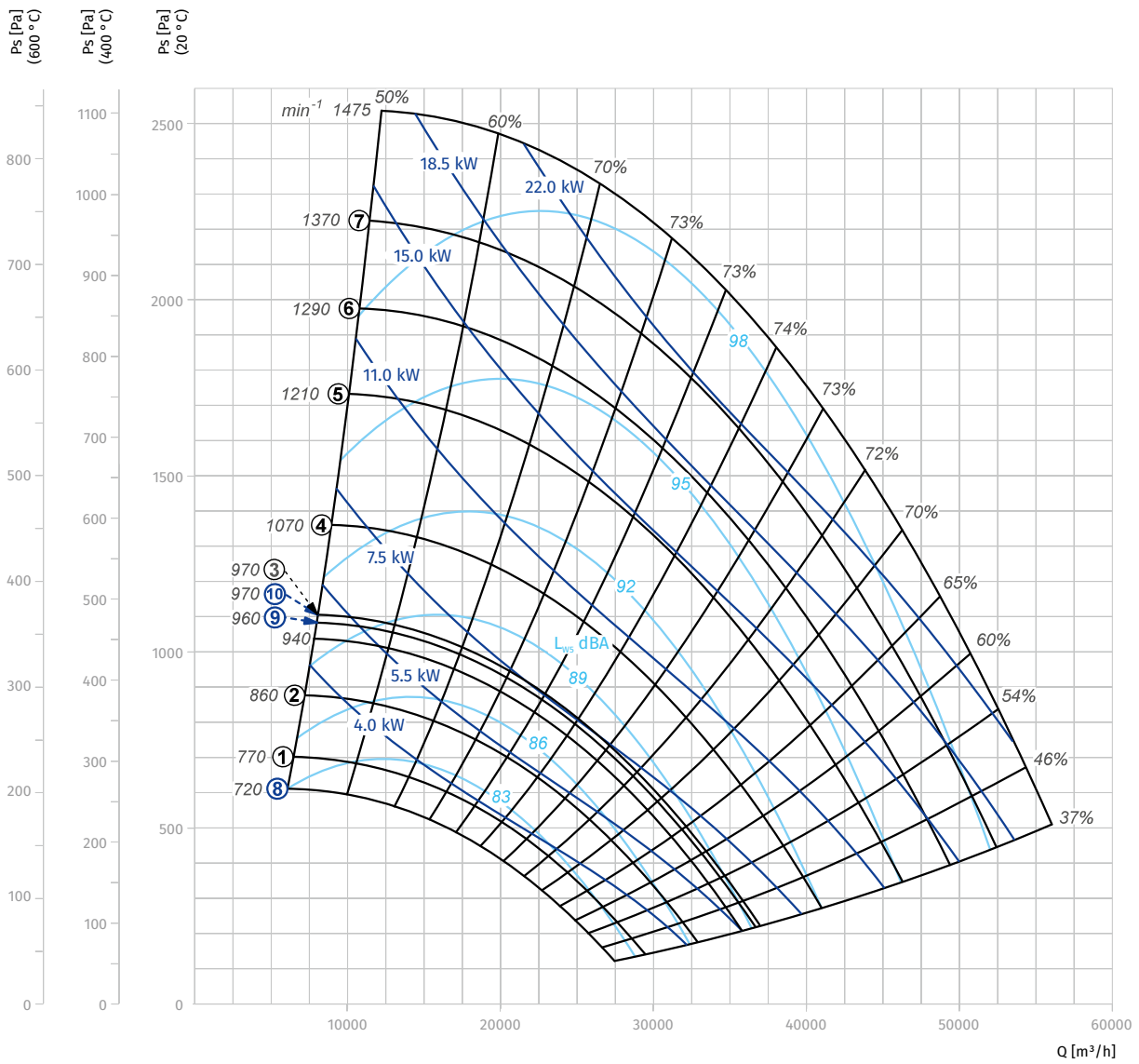

ROOF-MOUNTED SMOKE EXTRACTION FANS

Parameters	Tower-SV/SH 1000 5.5/720	Tower-SV/SH 1000 7.5/730	Tower-SV/SH 1000 11/970	Tower-SV/SH 1000 15/970	Tower-SV/SH 1000 18.5/970	Tower-SV/SH 1000 22/970	Tower-SV/SH 1000 30/970
Voltage [V]	3~400	3~400	3~400	3~400	3~400	3~400	3~400
Rated frequency [Hz]	50	50	50	50	50	50	50
Rated power Ny [kW]	5.5	7.5	11.0	15.0	18.5	22.0	30.0
Rated current [A]	13.6	18	23.0	31.0	36.5	44.6	59.6
Rated RPM [min ⁻¹]	720	730	970	970	970	970	970
Maximum RPM when operating from FC [min ⁻¹]	690	770	880	990	1060	1110	1230
Maximum frequency when operating from FC [Hz]	48	53	45	51	55	57	63
Curve number at the diagram when operating from FC	①	②	③	④	⑤	⑥	⑦
Curve number at the diagram when operating from supply network	-	⑧	-	⑨	⑨	⑨	⑨

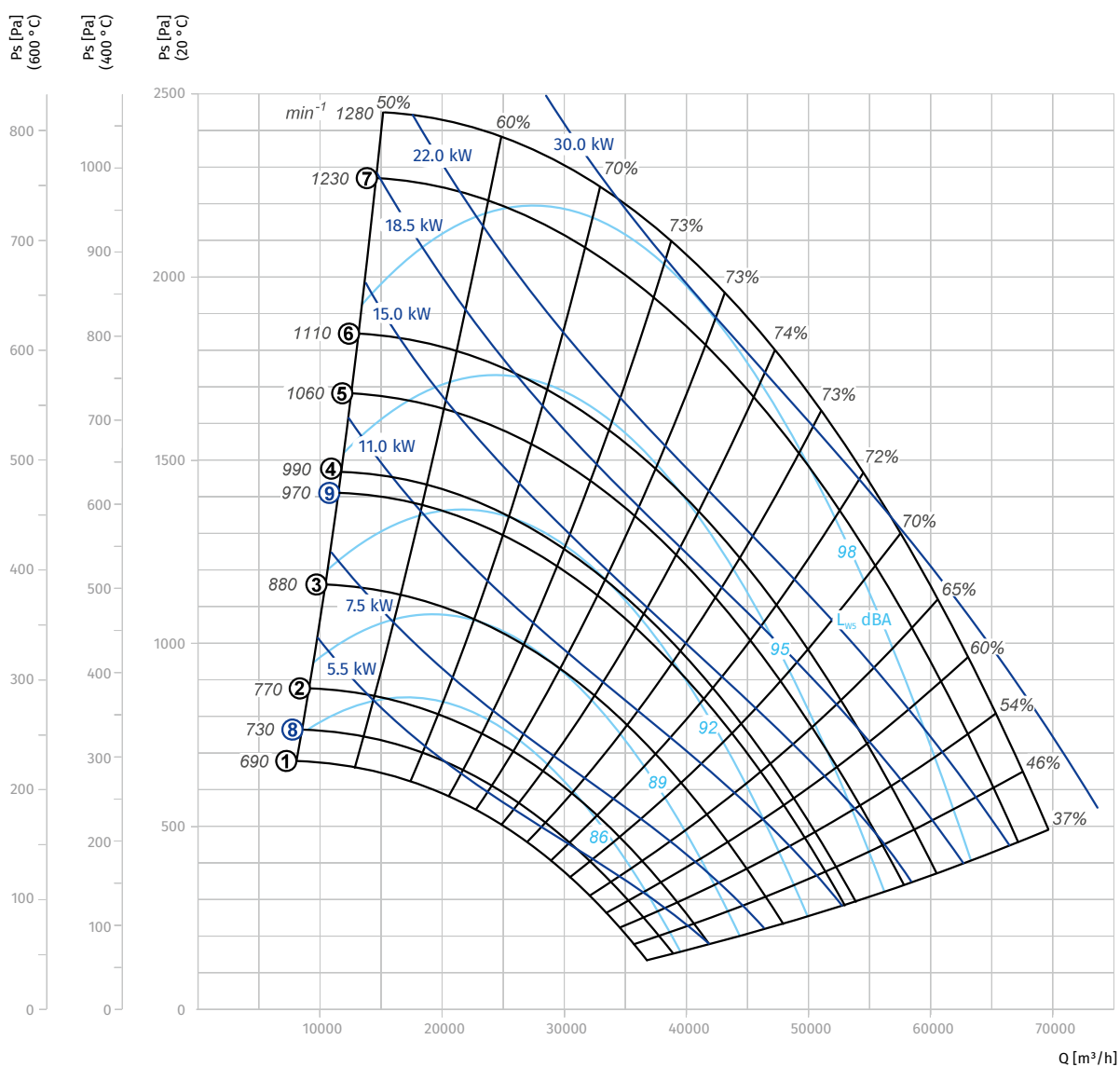

Parameters	Tower-SV/SH 1100 11/730	Tower-SV/SH 1100 15/730	Tower-SV/SH 1100 18.5/970	Tower-SV/SH 1100 22/970	Tower-SV/SH 1100 30/970	Tower-SV/SH 1100 37/980
Voltage [V]	3~400	3~400	3~400	3~400	3~400	3~400
Rated frequency [Hz]	50	50	50	50	50	50
Rated power Ny [kW]	11.0	15.0	18.5	22.0	30.0	37.0
Rated current [A]	25.1	32.3	36.5	44.6	59.6	70.0
Rated RPM [min ⁻¹]	730	730	970	970	970	980
Maximum RPM when operating from FC [min ⁻¹]	715	775	830	880	980	1040
Maximum frequency when operating from FC [Hz]	49	53	43	45	51	53
Curve number at the diagram when operating from FC	①	②	③	④	⑤	⑥
Curve number at the diagram when operating from supply network	-	⑦	-	-	⑧	⑨

